

Notes:

1. Electrical Characteristics:
  - 1-1. Rating: 2A (Pin 1/5), 0.5A (Pin 2/3/4).
  - 1-2. Contact Resistance: 30mohm Max.(Initial), 60mohm Max.(Final)
  - 1-3. Dielectric Withstanding Voltage: 500V AC for One Minute.
  - 1-4. Insulation Resistance: 100Mohm Min. Measure By 500 VDC.
2. Mechanical Characteristics:
  - 2-1. Plug Insertion Force: 35N Max.
  - 2-2. Plug Extraction Force: 8N Min.
3. Durability Test: 10,000 Cycles.
4. For Reflow Soldering Lead-Free Process.
5. Soldering Heat Resistance Reflow Soldering 260°C.
6. Plug Interface Dimensions Conform To USB2.0 Spec.
7. Packaging: Tape & Reel.
8. Date Code: Y M DD XX

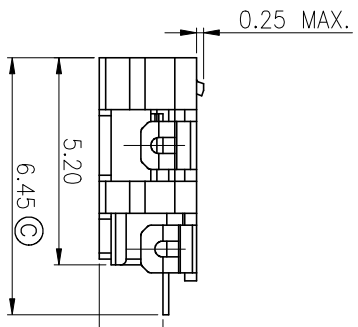

XX: PRODUCTION LINE  
 DD: DAY(01 ~ 31)  
 M: MONTH(1~9, X=10, Y=11, Z=12)  
 Y: YEAR(0~9)

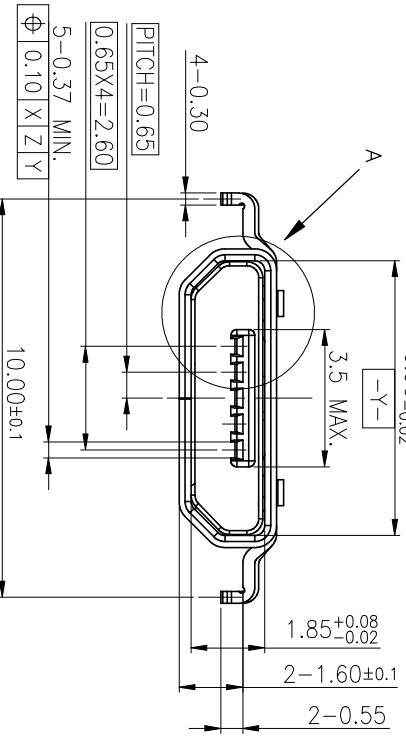
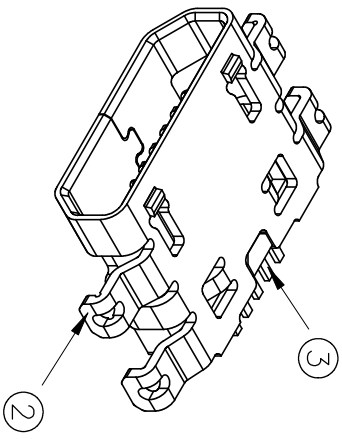
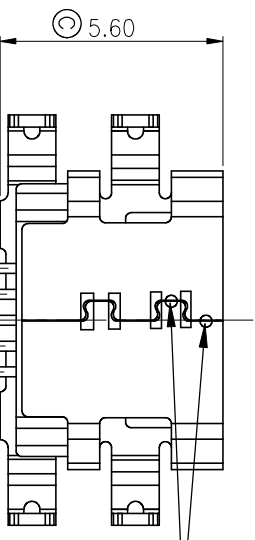

LASER WELDING POINT

**Simula Technology Inc.**  
 NOV 10. 2014  
**D.C.C. ISSUED**

ITEM	DESCRIPTIONS	MATERIAL	FINISH	Q'TY	NOTE
③	CONTACT	C2680-EH	CONTACT AREA Au 5μ" MIN. / SOLDER TAIL Au 2μ" MIN. OVER IN 80μ" MIN.	5	
②	SHELL	SUS304-3/4H	SOLDERABLE Nf: 50μ" MIN.	1	
①	HOUSING	LCP-E130i	UL94V-0-BLACK	1	

<b>LEAD-FREE</b> <b>HALOGEN-FREE</b>		<b>UNLESS OTHERWISE SPECIFIED DIMENSIONS ARE IN MILLIMETERS TOLERANCE DECIMAL ANGLES</b>	
.X ± 0.20	.X ± 0.20	.X ± 0.15	.X ± 0.15
.XX ± 0.15	.XX ± 0.15	.XX ± 0.15	.XX ± 0.15
<b>APPROVALS</b> DRAWN: Jack Yuan CHECKED: Johnny APPROVED: OK WU		<b>DATE</b> 2014/10/23 2014/10/23 2014/10/23	
<b>SIMULA</b> Superior Technology Solution Provider		<b>PART NO.</b> MJ817Y-5100-412	
<b>TITLE</b> CUSTOMER DRAWING MICRO USB B TYPE RECEPTACLE		<b>SCALE</b> 5:1	
<b>CONFIDENTIAL</b>		<b>UNIT</b> MM	
<b>3rd ANGLE PROJECTION</b>		<b>SHEET</b> 1/2	



CUSTOMER

REV.	DCN. NO.	ISSUED
Δ	PDR-1404300001 DCN-1410031	2014/10/23 Jack Yuen

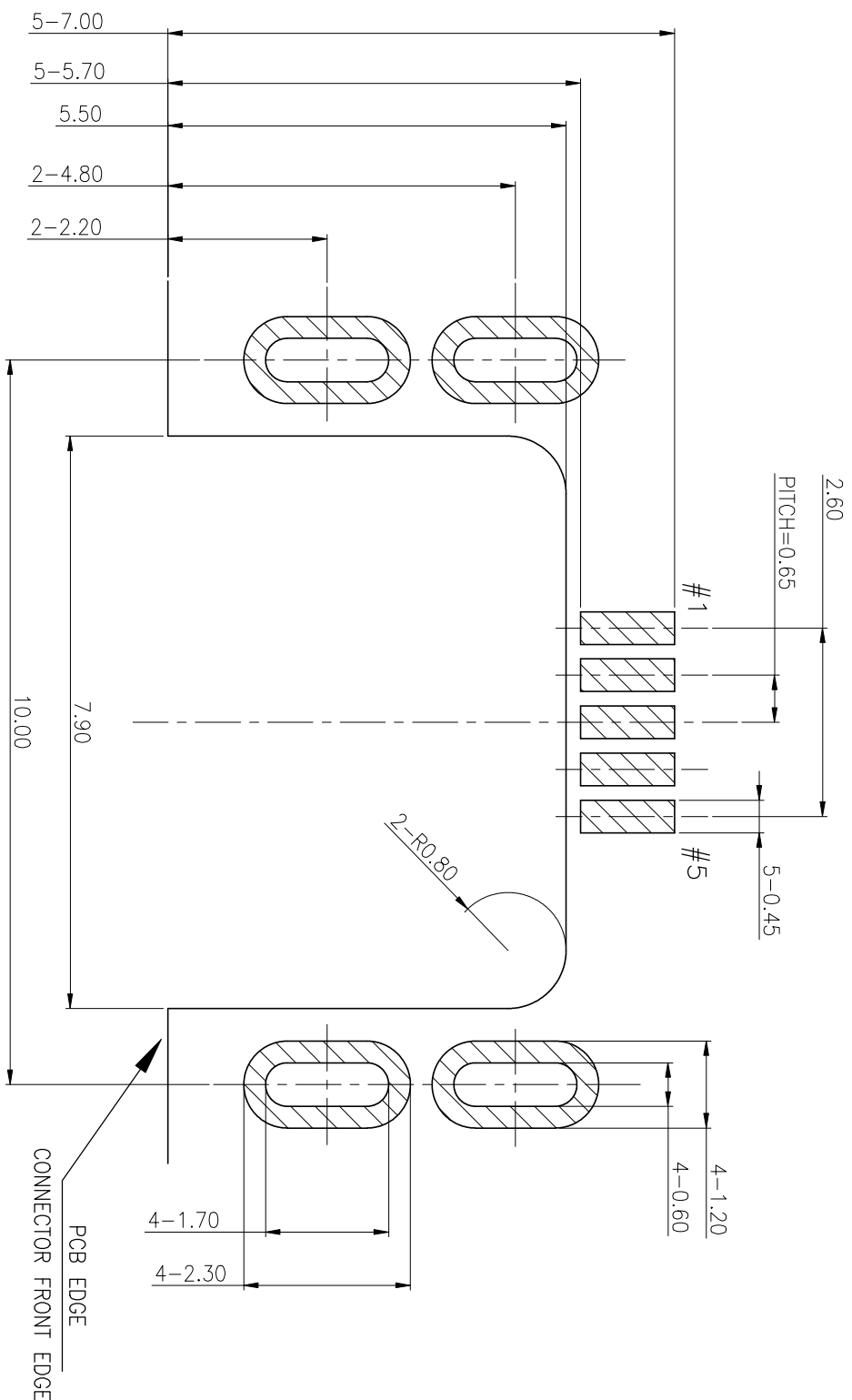
**Simula Technology Inc.**  
 NOV 10. 2014  
**D.C.C. ISSUED**

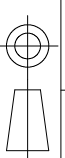

RECOMMENDED PCB LAYOUT  
 NOTE: TOLERANCE FOR PCB LAYOUT IS ±0.05mm  
 SCALE = 10:1

<b>■ LEAD-FREE</b> <b>■ HALOGEN-FREE</b>		<small>UNLESS OTHERWISE SPECIFIED          DIMENSION ARE IN MILLIMETER*          TOLERANCE ARE :          FRACTION DECIMAL ANGLES</small>	
.X ± 0.20	.X ± 0.15	.X ± 0.20	.X ± 0.15
 3rd ANGLE PROJECTION		 Superior Technology Solution Provider	
APPROVALS	DATE	TITLE	PART NO.
DRAWN: Jack Yuen	2014/10/23	CUSTOMER DRAWING	MJ817Y-5100-412
CHECKED: ohmy	2014/10/23	MICRO USB B TYPE RECEPTACLE	
APPROVED: CK WU	2014/10/23		
CONFIDENTIAL		SCALE	SHEET
		5:1	2/2

CUSTOMER