

REV.	DCN. NO.	ISSUED
A	PDR-13N236 DCN-1405027	2014/05/21 Perry/Chen
B	PDR-13N236 ECN-1409006	2014/09/18 Sky Mo

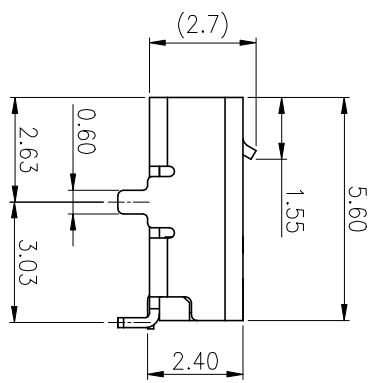
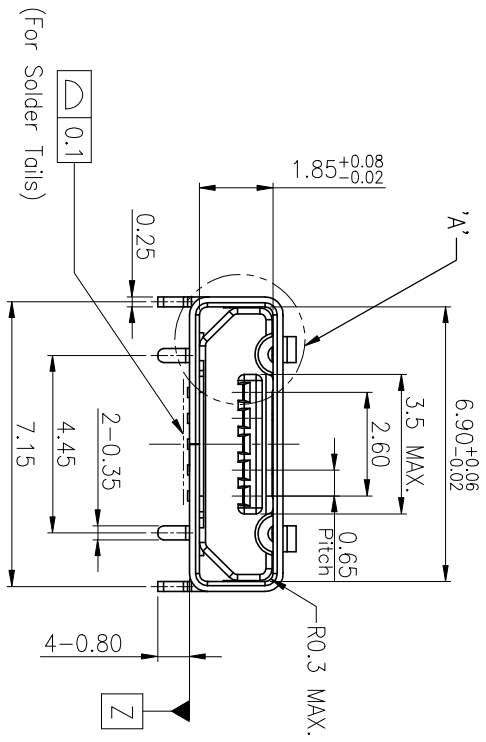
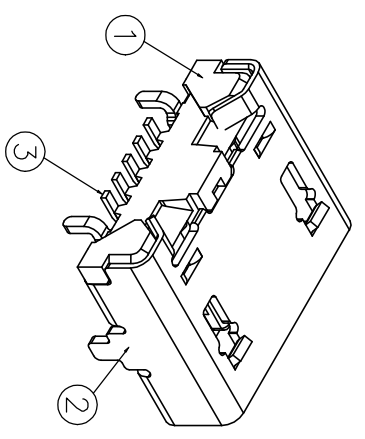
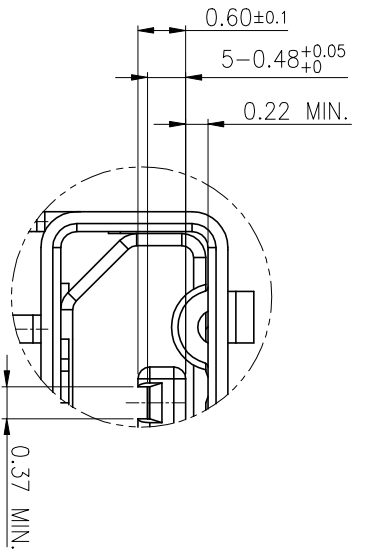
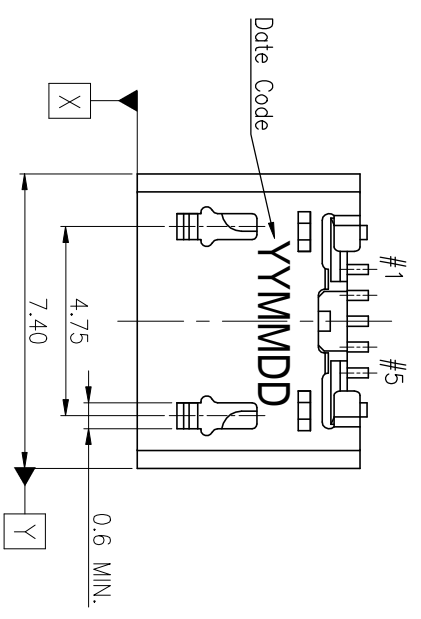

Notes:

- Electrical Characteristics:
 - 1-1. Rating: 2A (Pin 1/5), 0.5A (Pin 2/3/4).
 - 1-2. Contact Resistance: 30mohm Max.(Initial), 40mohm Max.(Final)
 - 1-3. Dielectric Withstanding Voltage: 500V AC for One Minute.
 - 1-4. Insulation Resistance: 100Mohm Min. Measure By 500 VDC.
- Mechanical Characteristics:
 - 2-1. Plug Insertion Force: 35N Max.
 - 2-2. Plug Extraction Force: 8N Min.
- Durability Test: 5,000 Cycles.
- For Reflow Soldering Lead-Free Process.
- Soldering Heat Resistance Reflow Soldering 260°C.
- Plug Interface Dimensions Conform To USB2.0 Spec.
- Packaging: Tape & Reel.
- Date Code: YY MM DD

DD: DAY(01 ~ 31)
MM: MONTH(01~12)
YY: YEAR(10~)

Simula Technology Inc.
SEP 25, 2014

D.C.C. ISSUED

ITEM	DESCRIPTIONS	MATERIAL	FINISH	Q'TY	NOTE
③	CONTACT	COPPER ALLOY	Au 1u" MIN. OVER Ni 50u" MIN.	5	
②	SHELL	STAINLESS STEEL	SOLDERABLE Ni 50u" MIN.	1	
①	HOUSING	THERMAL PLASTIC	U194V-0-BLACK	1	

LEAD-FREE <small>UNLESS OTHERWISE SPECIFIED DIMENSIONS ARE IN MILLIMETERS FRACTION DECIMAL ANGLES</small>	
.X ± 0.2	.X ± .5*
.XX ± 0.15	.X ± .5*

LEAD-FREE <small>UNLESS OTHERWISE SPECIFIED DIMENSIONS ARE IN MILLIMETERS FRACTION DECIMAL ANGLES</small>	
.X ± 0.2	.X ± .5*
.XX ± 0.15	.X ± .5*



PART NO. M0817S-5180-412

TITLE CUSTOMER DRAWING
U USB AB TYPE RECP/TACTLE

APPROVALS	DATE	SCALE	SHEET
SKY MO	2014/09/18	5:1	1/3

CUSTOMER

CONFIDENTIAL

REV.	DCN. NO.	ISSUED
△	PDR-13N236	2014/05/21
△	DCN-1205027	Perry/Chen
△	PDR-13N236	2014/09/18
△	ECN-1205006	Sky Mo

Simula Technology Inc.
 SEP 25, 2014
D.C.C. ISSUED

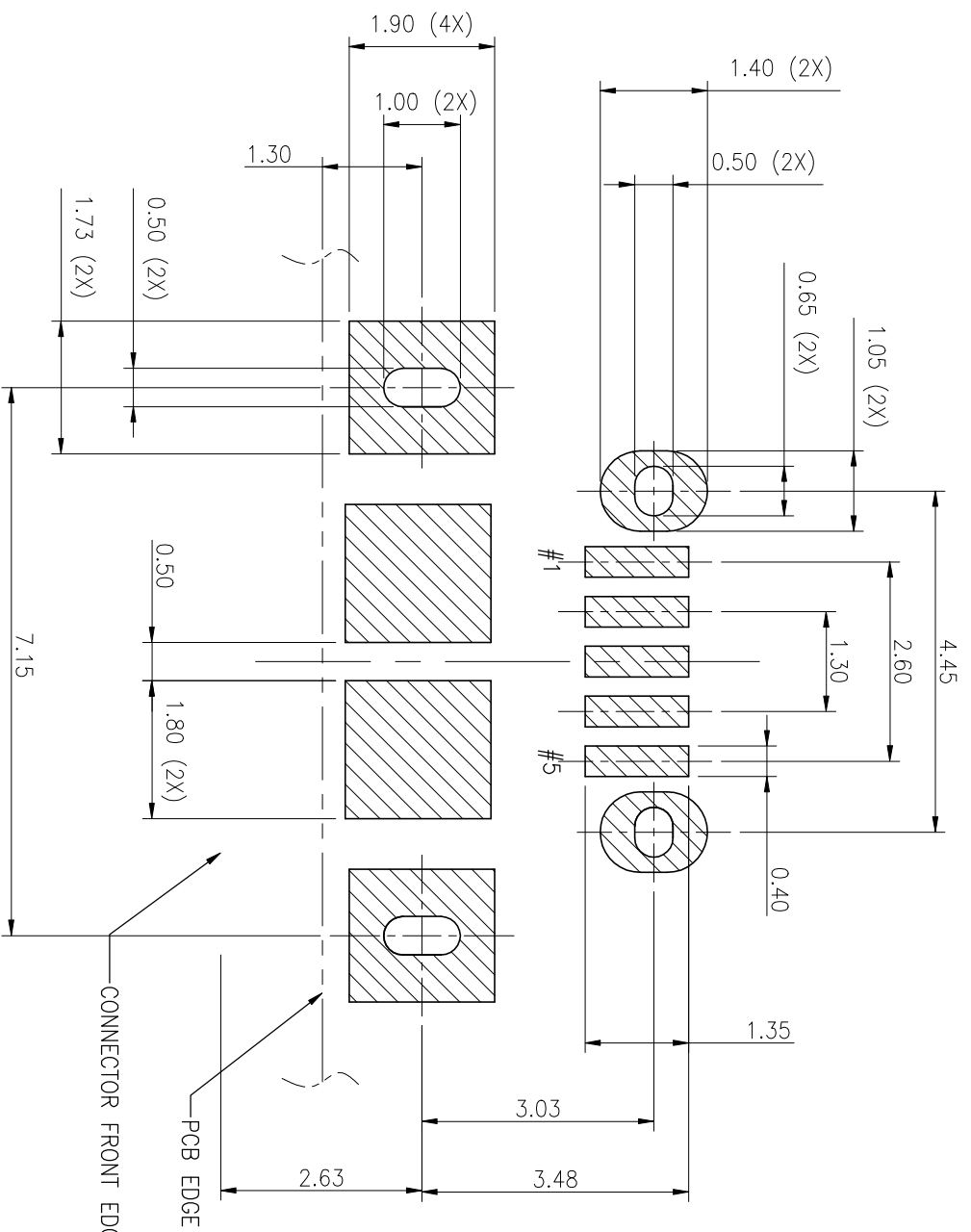

RECOMMENDED PCB LAYOUT
 NOTE: TOLERANCE FOR PCB LAYOUT IS ±0.05mm

 <small>Superior Technology Solution Provider</small>		PART NO. MJ817S-5180-412	
UNLESS OTHERWISE SPECIFIED DIMENSIONS ARE IN MILLIMETERS TOLERANCE ARE : FRACTION DECIMAL ANGLES		TITLE CUSTOMER DRAWING	
.X ± 0.2 .XX ± 0.15	X° ± 5° X' ± 5'	APPROVALS DRAWN Sky Mo CHECKED ANDY APPROVED JIM	DATE 2014/09/18 2014/09/18 2014/09/18
■ HALOGEN-FREE ■ LEAD-FREE		SIZE VERSION B	CUSST. NO. 10-1
3rd ANGLE PROJECTION		SCALE 10:1	UNIT MM SHEET 2/3
CONFIDENTIAL			

CUSTOMER

REV.	DCN. NO.	ISSUED
△ A	PDR-13N236 DCN-1405027	2014/05/21 Perry/Chen
△ B	PDR-13N236 ECN-1409006	2014/09/18 Sky Mo

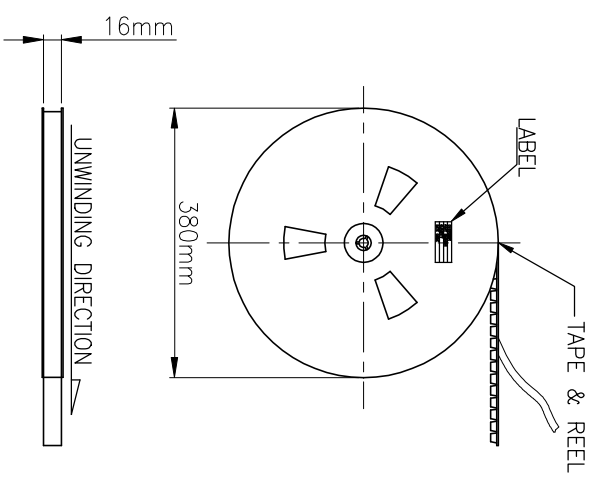
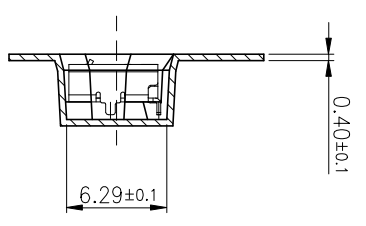
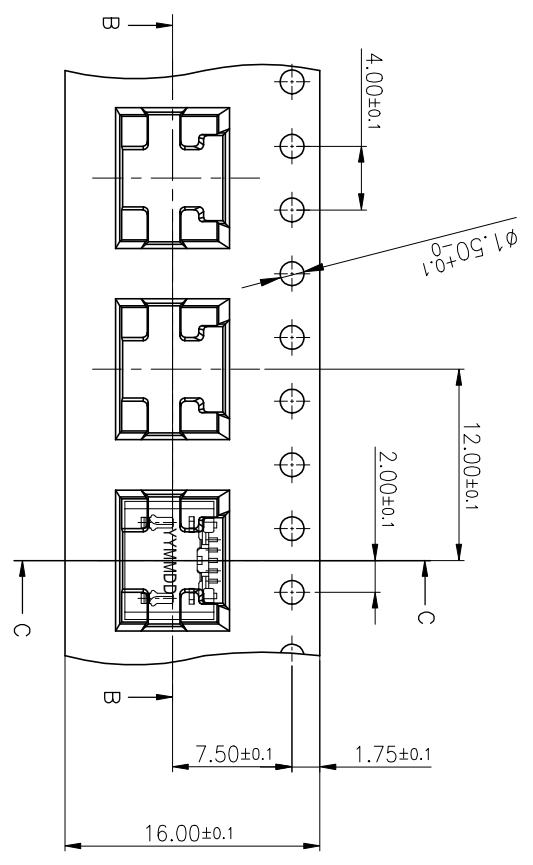
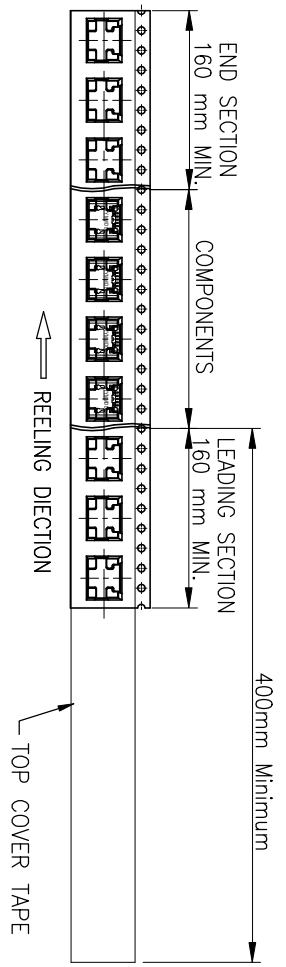
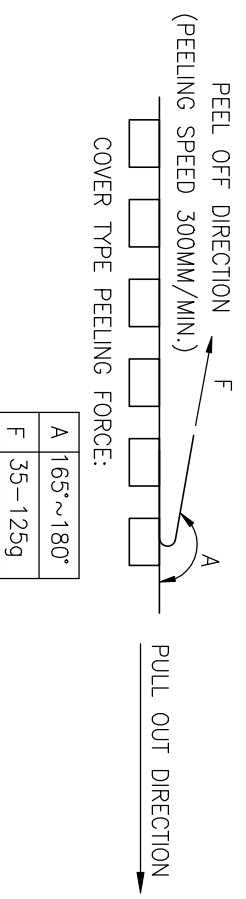

Simula Technology Inc.

SEP 25, 2014

D.C.C. ISSUED

- NOTES:
1. 10 SPROCKET HOLE PITCH CUMULATIVE TOLERANCE ±0.20.
 2. CARRIER CAMBER IS WITHIN 1 mm IN 250 mm.
 3. MATERIAL: TRANSPARENT CONDUCTIVE POLYSTYRENE ALLOY
 4. ALL DIMENSIONS MEET EIA-481-C REQUIREMENTS.
 5. THICKNESS : 0.40±0.05mm.
 6. COMPONENT LOAD PER 15°REEL 1800 PCS

UNLESS OTHERWISE SPECIFIED DIMENSION ARE IN MILLIMETERS TOLERANCE DECIMALS ANGLES

.X ± 0.2	.X° ± 5°
.XX ± 0.15	.X° ± 3°

3rd ANGLE PROJECTION

LEAD-FREE

HALOGEN-FREE

simula Superior Technology Solution Provider

PART NO. M0817S-5180-412

TITLE CUSTOMER DRAWING

U USB AB TYPE RECPPTACLE

SCALE 5:1 UNIT MM SHEET 3/3

APPROVALS

DRAWN	DATE
SKY Mo	2014/09/18
CHECKED	DATE
ANDY	2014/09/18
APPROVED	DATE
JIM	2014/09/18

CONFIDENTIAL

CUSTOMER